

GEC-Series Machine Screw Jack information

- 1: Model: GEC2.5, GEC5, GEC10, GEC20, GEC25, GEC35, GEC50, GEC100, GEC120
- 2: Load Capacities From 25KN to 1200KN As Standard.
- 3: Self Locking Trapezoidal Screw.
- 4: Translating Screw, Rotating Screw, Keyed Screw Configurations in Upright Or Inverted Mounting Orientation.

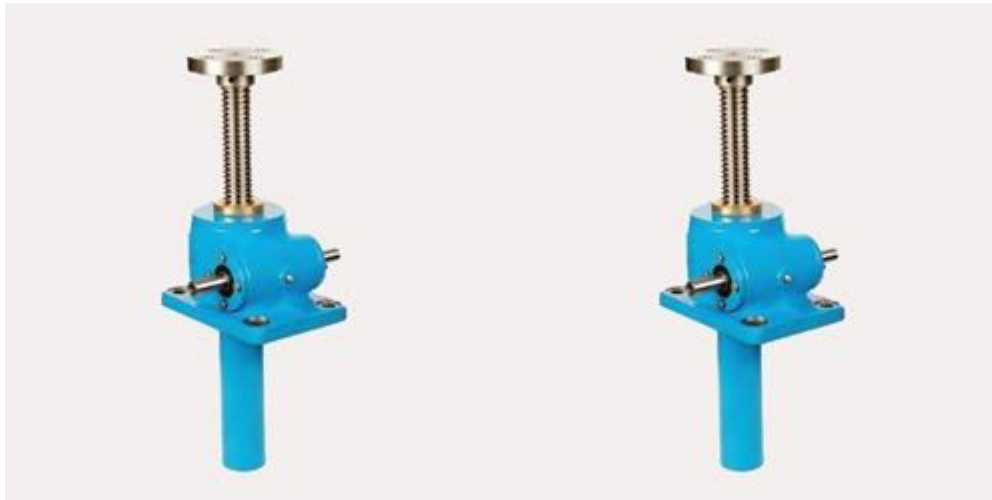

verter, Limited Switches, Linking Shaft,
ion Base



GEC-Series Machine Screw Jack Specifications:

Jack Model	GEC2.5	GEC5	GEC10/15	GEC20	GEC25	GEC35	GEC50	GEC100	GEC120
Max. Lifting Force (KN)	25	50	100/150	200	250	350	500	1000	1200
Max. Pulling Force(KN)	25	50	99	166	250	350	500	1000	1200
Lift Screw Size(mm)	Tr30×6	Tr40×7	Tr58×12	Tr65×12	Tr90×16	Tr100×18	Tr120×20	Tr160×23	Tr180×25
Gear Ratio (H)	1/6	1/6	3/23	1/8	3/32	3/32	3/32	1/12	1/12
Travel length(mm) per full turn of worm Shaft (H)	1.0	1.167	1.565	1.5	1.5	1.69	1.87	1.92	2.083
Efficiency % (H)	23	21	23	21	19	18	15	13	12
Gear Ratio (L)	1/24	1/24	1/23	1/24	1/32	1/32	1/32	1/36	1/36
Travel length(mm) per full turn of worm Shaft (L)	0.25	0.292	0.5	0.5	0.5	0.56	0.625	0.638	0.694
Efficiency % (L)	14	12	15	13	11	11	11	10	8
Max. Length of lifting screw (mm), when tensile force	1500	2000	2500	3000	3500	4000	5500	6500	7000
Max. Permissible power (KW)	1.45	2.59	3.47	4.02	5.38	13.06	13.9	28.5	62
Lubricant (kg)	0.1	0.25	0.5	0.75	1.1	1.9	2.2	2.5	2.5
Weight without stroke (kg)	7.3	16.2	25	36	70.5	87	420	1010	1350
Weight of screw (kg), per 100mm stroke	0.45	0.82	1.67	2.15	4.15	5.20	7.45	13.6	17.3

Remarks:

1: H: high ratio, L: low ratio.

2: Max. Permissible power is under the conditions that ambient temperature 20 degree c , duty cycle 20%h and input speed 1500rpm.

3: Efficiency is under grease lubrication.

4: Working temperature is -20°C-+80°C.

5: Self-locking under static conditions.

GEC2.5 Machine Screw Jack (Tr30×6)

Speed (rpm)	Lifting Speed (mm/min)		F=25KN		F=20KN		F=15KN		F=10KN	
			H	L	H	L	H	L	H	L
			18 N.m	7.1 N.m	14 N.m	5.7 N.m	11 N.m	4.3 N.m	6.9N.m	2.9N.m
	H:1/6	L:1/24	(KW)	(KW)	(KW)	(KW)	(KW)	(KW)	(KW)	(KW)
1500	1500	375	2.7	1.2	2.2	0.89	1.7	0.67	1.1	0.45
1000	1000	250	1.8	0.74	1.5	0.60	1.1	0.45	0.72	0.30
750	750	187.5	1.4	0.56	1.1	0.45	0.82	0.33	0.54	0.22
500	500	125	0.91	0.37	0.72	0.30	0.54	0.22	0.36	0.15
300	300	75	0.54	0.22	0.43	0.18	0.33	0.13	0.22	0.09
200	200	50	0.36	0.15	0.29	0.12	0.22	0.09	0.14	0.06
100	100	25	0.18	0.07	0.14	0.06	0.11	0.05	0.07	0.05
50	50	12.5	0.09	0.05	0.07	0.05	0.05	0.05	0.05	0.05
Speed (rpm)	Lifting Speed (mm/min)		F=5KN		F=2.5KN		F=1KN			
			H	L	H	L	H	L		
			3.5 N.m	1.4 N.m	1.7 N.m	0.71 N.m	11 N.m	4.3 N.m		
	H:1/6	L:1/24	(KW)	(KW)	(KW)	(KW)	(KW)	(KW)		
1500	1500	375	0.54	0.22	0.27	0.11	0.11	0.05		
1000	1000	250	0.36	0.15	0.18	0.07	0.07	0.05		
750	750	187.5	0.27	0.11	0.14	0.06	0.05	0.05		
500	500	125	0.18	0.07	0.09	0.05	0.05	0.05		
300	300	75	0.11	0.05	0.05	0.05	0.05	0.05		
200	200	50	0.07	0.05	0.05	0.05	0.05	0.05		
100	100	25	0.05	0.05	0.05	0.05	0.05	0.05		
50	50	12.5	0.05	0.05	0.05	0.05	0.05	0.05		

GEC5 Machine Screw Jack (Tr40×7)

Speed (rpm)	Lifting Speed (mm/min)		F=50KN		F=40KN		F=30KN		F=20KN	
			H	L	H	L	H	L	H	L
			44.2 N.m	19.3 N.m	35.4 N.m	15.5 N.m	26.5 N.m	11.6 N.m	17.7N.m	7.7N.m
	H:1/6	L:1/24	(KW)	(KW)	(KW)	(KW)	(KW)	(KW)	(KW)	(KW)
1500	1750	438	6.9	3.0	5.6	2.4	4.2	1.8	2.8	1.2
1000	1167	292	4.6	2.0	3.7	1.6	2.8	1.2	1.9	0.8
750	875	219	3.5	1.5	2.8	1.2	2.1	0.9	1.4	0.6
500	583	146	2.3	1.0	1.9	0.8	1.4	0.6	0.9	0.4
300	350	88	1.4	0.6	1.1	0.5	0.8	0.4	0.6	0.2
200	233	58	0.9	0.4	0.7	0.3	0.6	0.2	0.4	0.2
100	29	0.5	0.4	0.2	0.4	0.2	0.3	0.1	0.2	0.1
50	15	0.2	0.2	0.1	0.2	0.1	0.1	0.1	0.1	0.1
Speed (rpm)	Lifting Speed (mm/min)		F=10KN		F=5KN		F=2.5KN			
			H	L	H	L	H	L		
			8.8 N.m	3.9 N.m	4.4 N.m	1.9 N.m	2.2 N.m	1.0 N.m		
	H:1/6	L:1/24	(KW)	(KW)	(KW)	(KW)	(KW)	(KW)		
1500	1750	438	1.4	0.6	0.7	0.3	0.3	0.2		
1000	1167	292	0.9	0.4	0.5	0.2	0.2	0.1		
750	875	219	0.7	0.3	0.3	0.2	0.2	0.1		

500	583	146	0.5	0.2	0.2	0.1	0.1	0.1		
300	350	88	0.3	0.1	0.1	0.1	0.1	0.1		
200	233	58	0.2	0.1	0.1	0.1	0.1	0.1		
100	29	0.5	0.1	0.1	0.1	0.1	0.1	0.1		
50	15	0.2	0.1	0.1	0.1	0.1	0.1	0.1		

GEC10 Machine Screw Jack (Tr58×12)

Speed (rpm)	Lifting Speed (mm/min)		F=100KN		F=80KN		F=60KN		F=40KN	
			H	L	H	L	H	L	H	L
			108 N.m	53 N.m	87 N.m	43 N.m	65 N.m	32 N.m	44 N.m	22 N.m
	H:3/23:1	L:1/23	(KW)	(KW)	(KW)	(KW)	(KW)	(KW)	(KW)	(KW)
1500	2348	750	17	8.3	14	6.7	11	5.0	6.8	3.3
1000	1565	500	12	5.6	9.1	4.4	6.8	3.3	4.5	2.2
750	1174	375	8.5	4.2	6.8	3.3	5.1	2.5	3.4	1.7
500	783	250	5.7	2.8	4.5	2.2	3.4	1.7	2.3	1.1
300	470	150	3.4	1.7	2.7	1.3	2.0	1.0	1.4	0.7
200	313	100	2.3	1.1	1.8	0.9	1.4	0.7	0.9	0.4
100	157	50	1.1	0.6	0.9	0.4	0.7	0.3	0.5	0.2
50	78	25	0.6	0.3	0.5	0.2	0.3	0.2	0.2	0.1
Speed (rpm)	Lifting Speed (mm/min)		F=20KN		F=10KN		F=5KN			
			H	L	H	L	H	L		
			22 N.m	11 N.m	11N.m	5.3 N.m	5.4 N.m	2.7 N.m		
	H:3/23:1	L:1/23	(KW)	(KW)	(KW)	(KW)	(KW)	(KW)		
1500	2348	750	3.4	1.7	1.7	0.8	0.9	0.4		
1000	1565	500	2.3	1.1	1.1	0.6	0.6	0.3		
750	1174	375	1.7	0.8	0.9	0.4	0.4	0.2		
500	783	250	1.1	0.6	0.6	0.3	0.3	0.1		
300	470	150	0.7	0.3	0.3	0.2	0.2	0.1		
200	313	100	0.5	0.2	0.2	0.1	0.1	0.1		
100	157	50	0.2	0.1	0.1	0.1	0.1	0.1		
50	78	25	0.1	0.1	0.1	0.1	0.1	0.1		

GEC20 Machine Screw Jack (Tr65×12)

Speed (rpm)	Lifting Speed (mm/min)		F=200KN		F=160KN		F=120KN		F=100KN	
			H	L	H	L	H	L	H	L
			228 N.m	123 N.m	182 N.m	98 N.m	137 N.m	74 N.m	114 N.m	62 N.m
	H:1/8	L:1/24	(KW)	(KW)	(KW)	(KW)	(KW)	(KW)	(KW)	(KW)
1500	2250	750	36	20	29	16	22	12	18	9.6
1000	1500	500	24	13	19	11	15	7.7	12	6.4
750	1125	375	18	9.6	15	7.7	11	5.8	8.9	4.8
500	750	250	12	6.4	9.5	5.1	7.1	3.8	6.0	3.2
300	450	150	7.1	3.8	5.7	3.1	4.3	2.3	3.6	1.9
200	300	100	4.8	2.6	3.8	2.1	2.9	1.5	2.4	1.3
100	150	50	2.4	1.3	1.9	1.0	1.4	0.8	1.2	0.6
50	75	25	1.2	0.6	1.0	0.5	0.7	0.4	0.6	0.3
			F= 75 KN		F=50KN		F=25KN			

Speed (rpm)	Lifting Speed (mm/min)		H	L	H	L	H	L		
			86 N.m	46 N.m	57N.m	31 N.m	29 N.m	16 N.m		
	H:1/8	L:1/24	(KW)	(KW)	(KW)	(KW)	(KW)	(KW)		
1500	2250	750	14	7.2	8.9	4.8	4.5	2.4		
1000	1500	500	8.9	4.8	6.0	3.2	3.0	1.6		
750	1125	375	6.7	3.6	4.5	2.4	2.2	1.2		
500	750	250	4.5	2.4	3.0	1.6	1.5	0.8		
300	450	150	2.7	1.4	1.8	1.0	0.9	0.5		
200	300	100	1.8	1.0	1.2	0.6	0.6	0.3		
100	150	50	0.9	0.5	0.6	0.3	0.3	0.2		
50	75	25	0.4	0.2	0.3	0.2	0.1	0.1		

GEC25 Machine Screw Jack (Tr90×16)

Speed (rpm)	Lifting Speed (mm/min)		F=250KN		F=200KN		F=160KN		F=120KN	
			H	L	H	L	H	L	H	L
			314 N.m	181 N.m	252 N.m	145 N.m	201 N.m	116 N.m	151 N.m	87 N.m
	H:3/32	L:1/32	(KW)	(KW)	(KW)	(KW)	(KW)	(KW)	(KW)	(KW)
1500	1500	500	33	19	27	16	22	13	16	9.1
1000	1125	375	25	15	20	12	16	9.1	12	6.8
750	750	250	17	9.5	14	7.6	11	6.1	7.9	4.5
500	600	200	14	7.6	11	6.1	8.4	4.8	6.3	3.6
300	450	150	9.9	5.7	7.9	4.5	6.3	3.6	4.7	2.7
200	300	100	6.6	3.8	5.3	3.0	4.2	2.4	3.2	1.8
100	150	50	3.3	1.9	2.6	1.5	2.1	1.2	1.6	0.9
50	75	25	1.6	0.9	1.3	0.8	1.1	0.6	0.8	0.5
Speed (rpm)	Lifting Speed (mm/min)		F= 100 KN		F=75KN		F=50KN			
			H	L	H	L	H	L		
			126 N.m	73 N.m	95 N.m	55 N.m	63 N.m	37 N.m		
	H:3/32	L:1/32	(KW)	(KW)	(KW)	(KW)	(KW)	(KW)		
1500	1500	500	14	7.6	9.9	5.7	6.6	3.8		
1000	1125	375	9.9	5.7	7.4	4.3	4.9	2.8		
750	750	250	6.6	3.8	4.9	2.8	3.3	1.9		
500	600	200	5.3	3.0	3.9	2.3	2.6	1.5		
300	450	150	3.9	2.3	3.0	1.7	2.0	1.1		
200	300	100	2.6	1.5	2.0	1.1	1.3	0.8		
100	150	50	1.3	0.8	1.0	0.6	0.7	0.4		
50	75	25	0.7	0.4	0.5	0.3	0.3	0.2		

GEC35 Machine Screw Jack (Tr100×18)

Speed (rpm)	Lifting Speed (mm/min)		F=350KN		F=300KN		F=250KN		F=200KN	
			H	L	H	L	H	L	H	L
			464 N.m	253 N.m	398 N.m	217 N.m	332 N.m	181 N.m	266 N.m	145 N.m
	H:3/32	L:1/32	(KW)	(KW)	(KW)	(KW)	(KW)	(KW)	(KW)	(KW)
1500	1500	500	49	27	42	23	35	19	28	16
1000	1125	375	37	20	32	17	26	15	21	12
750	750	250	25	14	21	12	18	9.5	14	7.6

500	600	200	20	11	17	9.1	14	7.6	12	6.1
300	450	150	15	8.0	13	6.8	11	5.7	8.3	4.5
200	300	100	9.8	5.3	8.4	4.5	7.0	3.8	5.6	3.0
100	150	50	4.9	2.7	4.2	2.3	3.5	1.9	2.8	1.5
50	75	25	2.5	1.3	2.1	1.1	1.8	0.9	1.4	0.8
Speed (rpm)	Lifting Speed (mm/min)		F=150KN		F=100KN		F=50KN			
			H	L	H	L	H	L		
			199 N.m	109 N.m	133 N.m	73 N.m	67 N.m	36 N.m		
	H:3/32	L:1/32	(KW)	(KW)	(KW)	(KW)	(KW)	(KW)		
1500	1500	500	21	12	14	7.6	6.9	3.8		
1000	1125	375	16	8.5	11	5.7	5.2	2.8		
750	750	250	11	5.7	6.9	3.8	3.5	1.9		
500	600	200	8.3	4.5	5.6	3.0	2.8	1.5		
300	450	150	6.3	3.4	4.2	2.3	2.1	1.1		
200	300	100	4.2	2.3	2.8	1.5	1.4	0.8		
100	150	50	2.1	1.1	1.4	0.8	0.7	0.4		
50	75	25	1.0	0.6	0.7	0.4	0.3	0.3		

GEC50 Machine Screw Jack (Tr120×20)										
Speed (rpm)	Lifting Speed (mm/min)		F=500KN		F=450KN		F=400KN		F=350KN	
			H	L	H	L	H	L	H	L
			848 N.m	448 N.m	764 N.m	401 N.m	679 N.m	353 N.m	594 N.m	316 N.m
	H:3/32	L:1/32	(KW)	(KW)	(KW)	(KW)	(KW)	(KW)	(KW)	(KW)
1500	1600	625	88	47	80	42	71.1	37	62.2	33.1
1000	1200	469	67	35.5	60	31	53.3	28.4	46.5	24.8
750	800	313	44	23.7	40	21	35.5	18.9	31	16.6
500	640	250	35	18.9	32	17	28.4	15.2	24.8	13.3
300	480	188	26	14.2	24	12.8	21.3	11.4	18.6	9.9
200	320	125	18	9.5	16	8.5	14.2	7.5	12.4	6.6
100	160	60	8.9	4.5	8	4	7.1	3.6	6.2	3.2
50	80	30	4.4	2.2	4	2	3.5	1.8	3.1	1.6
Speed (rpm)	Lifting Speed (mm/min)		F=300KN		F=200KN		F=100KN			
			H	L	H	L	H	L		
			509 N.m	271 N.m	339 N.m	180 N.m	169 N.m	90 N.m		
	H:3/32	L:1/32	(KW)	(KW)	(KW)	(KW)	(KW)	(KW)		
1500	1600	625	53.3	28.4	35.5	18.9	17.7	9.4		
1000	1200	469	39.3	21.3	26.7	14.2	13.4	7.1		
750	800	313	26.2	14.2	17.7	9.5	8.9	4.7		
500	640	250	21.3	11.4	14.2	7.6	7.1	3.8		
300	480	188	16	8.5	10.7	5.7	5.3	2.9		
200	320	125	1.6	5.7	7.1	3.7	3.5	1.8		
100	160	60	5.3	2.8	3.5	1.8	1.7	0.9		
50	80	30	2.6	1.3	1.7	0.9	0.8	0.45		

GEC100 Machine Screw Jack (Tr160×23)										
			F=1000KN		F=900KN		F=800KN		F=700KN	

Speed (rpm)	Lifting Speed (mm/min)		H	L	H	L	H	L	H	L
			1938N.m	1012N.m	1747N.m	915 N.m	1554 N.m	813 N.m	1359N.m	711N.m
	H:1/12	L:1/36	(KW)	(KW)	(KW)	(KW)	(KW)	(KW)	(KW)	(KW)
1500	1586	639	203	106	183	96	162	85	142	74
1000	1189	479	152	80	137	72	122	64	106	55
750	793	319	102	53	91	48	81	42	71	37
500	635	255	81.4	42.5	73	38	65	34	56	29
300	476	192	61	32	55	28.8	49	25	42	22
200	317	128	40.6	21	36	19.2	32.5	17	28	15
100	159	64	20.3	10.6	18.3	9.6	16	8.5	14	7.5
50	80	32	10.2	5.3	9.1	4.8	8	4.2	7	3.8
Speed (rpm)	Lifting Speed (mm/min)		F=600KN		F=400KN		F=200KN			
			H	L	H	L	H	L		
			1165N.m	611 N.m	776 N.m	406 N.m	388 N.m	203 N.m		
	H:1/12	L:1/36	(KW)	(KW)	(KW)	(KW)	(KW)	(KW)		
1500	1586	639	122	64	81	42.6	40.6	21.3		
1000	1189	479	91	48	61	32	30.5	16		
750	793	319	61	32	41	21	21	10.5		
500	635	255	48	25.5	32	17	16	8.5		
300	476	192	36	19.2	24	12.7	12	6.3		
200	317	128	24	12.8	16	8.5	8	4.2		
100	159	64	12	6.4	8	4.3	4	2.1		
50	80	32	6	3.2	4	2.1	2	1.05		

GEC120 Machine Screw Jack (Tr180×25)

Speed (rpm)	Lifting Speed (mm/min)		F=1200KN		F=1000KN		F=900KN		F=800KN	
			H	L	H	L	H	L	H	L
			3315N.m	1656 N.m	2762N.m	1380 N.m	2486 N.m	1242N.m	2206N.m	1104N.m
	H:1/12	L:1/36	(KW)	(KW)	(KW)	(KW)	(KW)	(KW)	(KW)	(KW)
1500	2083	694	347	173	289	144	260	130	231	115
1000	1563	521	260	130	217	108	195	97	173	86
750	1042	347	173	87	144	72	130	65	115	57
500	833	277	138	69	115	57	104	51	92	46
300	625	208	104	52	86	43	78	39	69	35
200	417	139	69	34	58	28	52	26	46	23
100	208	69	34	17	29	14	26	13	23	11.5
50	104	35	17	8.5	14.5	7	13	6.5	11.5	5.7
Speed (rpm)	Lifting Speed (mm/min)		F=600KN		F=400KN		F=200KN			
			H	L	H	L	H	L		
			1657 N.m	828 N.m	1103N.m	552 N.m	551N.m	276 N.m		
	H:1/12	L:1/36	(KW)	(KW)	(KW)	(KW)	(KW)	(KW)		
1500	2083	694	173	86.5	115	57.5	57.5	28.8		
1000	1563	521	130	65	86	43	43	21.5		
750	1042	347	86	43.5	57	28.5	28.5	14.5		
500	833	277	69	34.5	46	23	23	11.5		
300	625	208	52	26	34.5	17.5	17.5	8.7		
200	417	139	34.5	17	23	11.5	11.5	5.7		
100	208	69	17	8.5	11.5	5.7	5.7	2.8		
50	104	35	8.5	4.2	5.7	2.8	2.8	1.4		

GEC-Series Machine Screw Jack Ordering Information.

GEC25 - US - T - C - 1/32 - 300 - Y
 1 2 3 4 5 6 7

1: Jack Model

GEC2.5, GEC5, GEC10, GEC20, GEC25, GEC35, GEC50, GEC100, GEC120.

2: Screw Configuration & Mounting Orientation

US: Upright translating screw

UK: Upright keyed screw

UR: Upright rotating screw

IS: Inverted translating screw

IK: Inverted keyed screw

IR: Inverted rotating screw

Note: US, IS (Screw rotation, do axial motion) UK, IK (Screw anti-rotation, do axial motion)

UR, IR (Screw fixed rotation, traveling nut do axial motion)

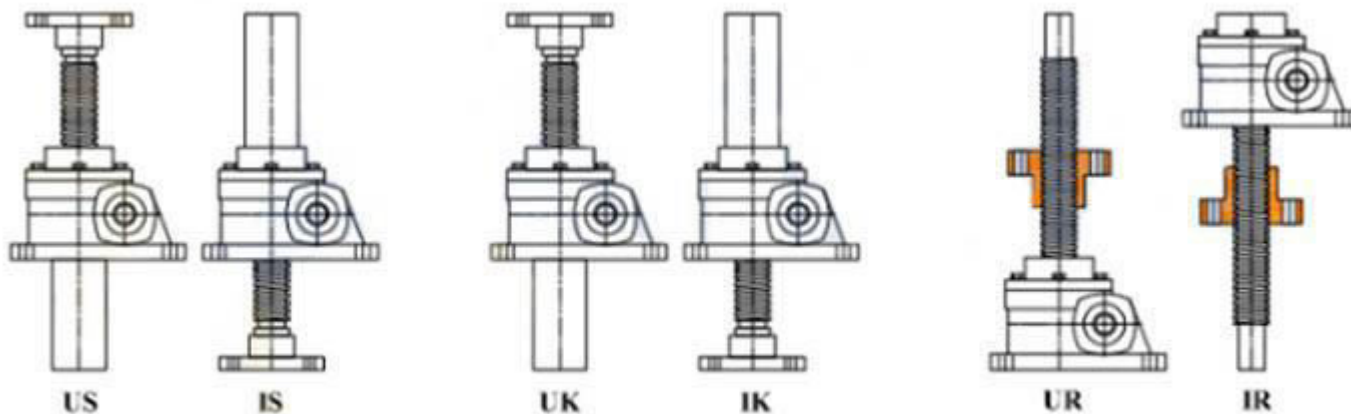

3: Screw Top End

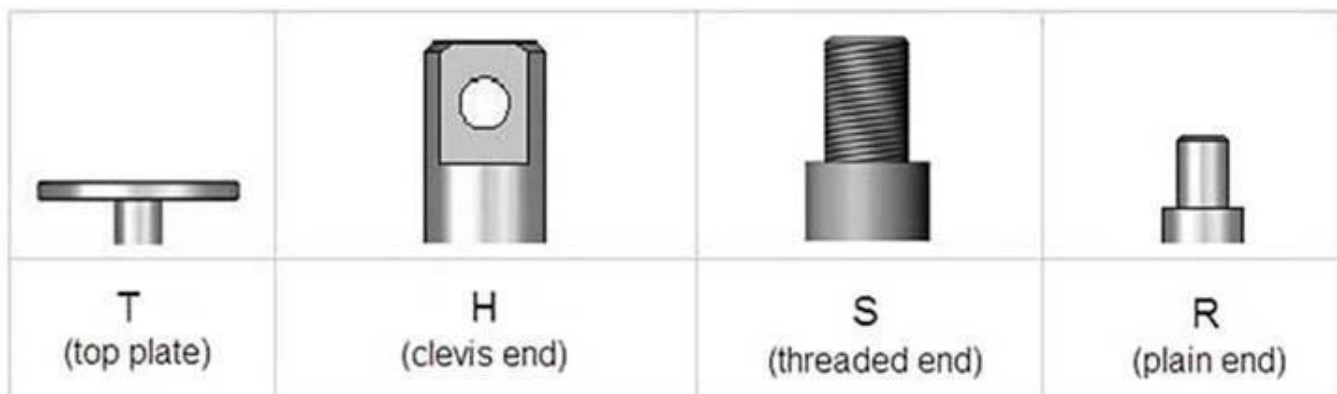

4: Worm Shaft Input Types

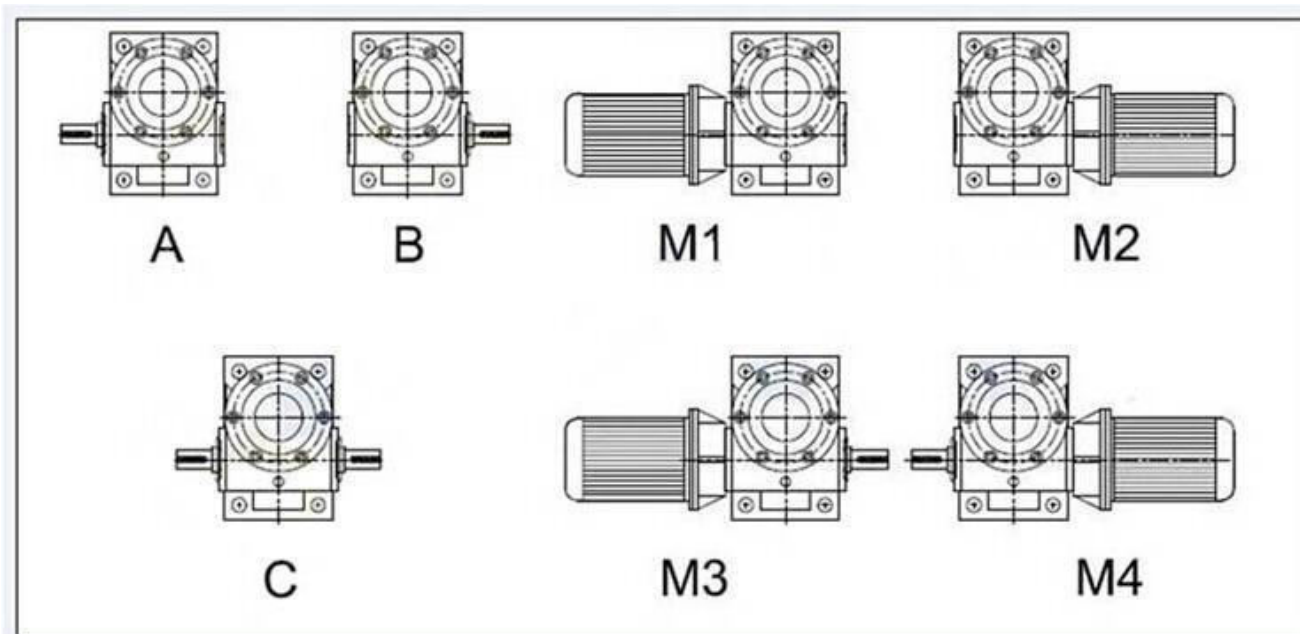

5 : Gear Ratio

GEC2.5: 1/6, 1/24.

GEC5: 1/6, 1/24.

GEC10: 3/23, 1/23.

GEC20: 1/8, 1/24.

GEC25: 3/32, 1/32

GEC35: 3/32, 1/32

GEC50: 3/32, 1/32

GEC100: 1/12, 1/36

GEC120: 1/12, 1/36.

6: Travel Stroke

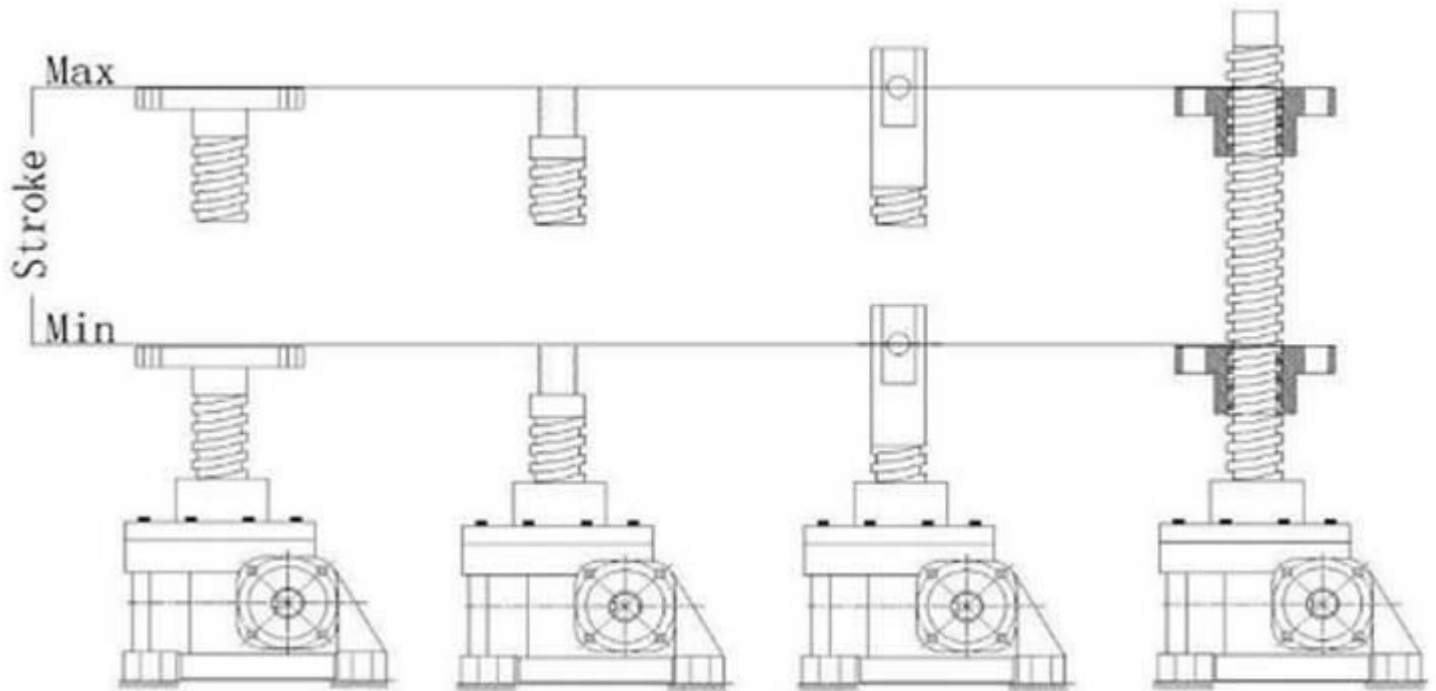

7: Accessories

N: Standard Jack, No additional accessories

P: Protective Tube

R: Rubber Bellow

Y: Hand Wheel



Steel cover



Rubber bellows



Hand wheel



Bevel Gearbox



swivel plate mounting base



limited switches



inverter



pillow block bearing



Gear Motor



Planetary Gear Reducer



DC12V/24V Motor



AC 100V-460V Motor

GEC2.5 Machine Screw Jack Dimensions:

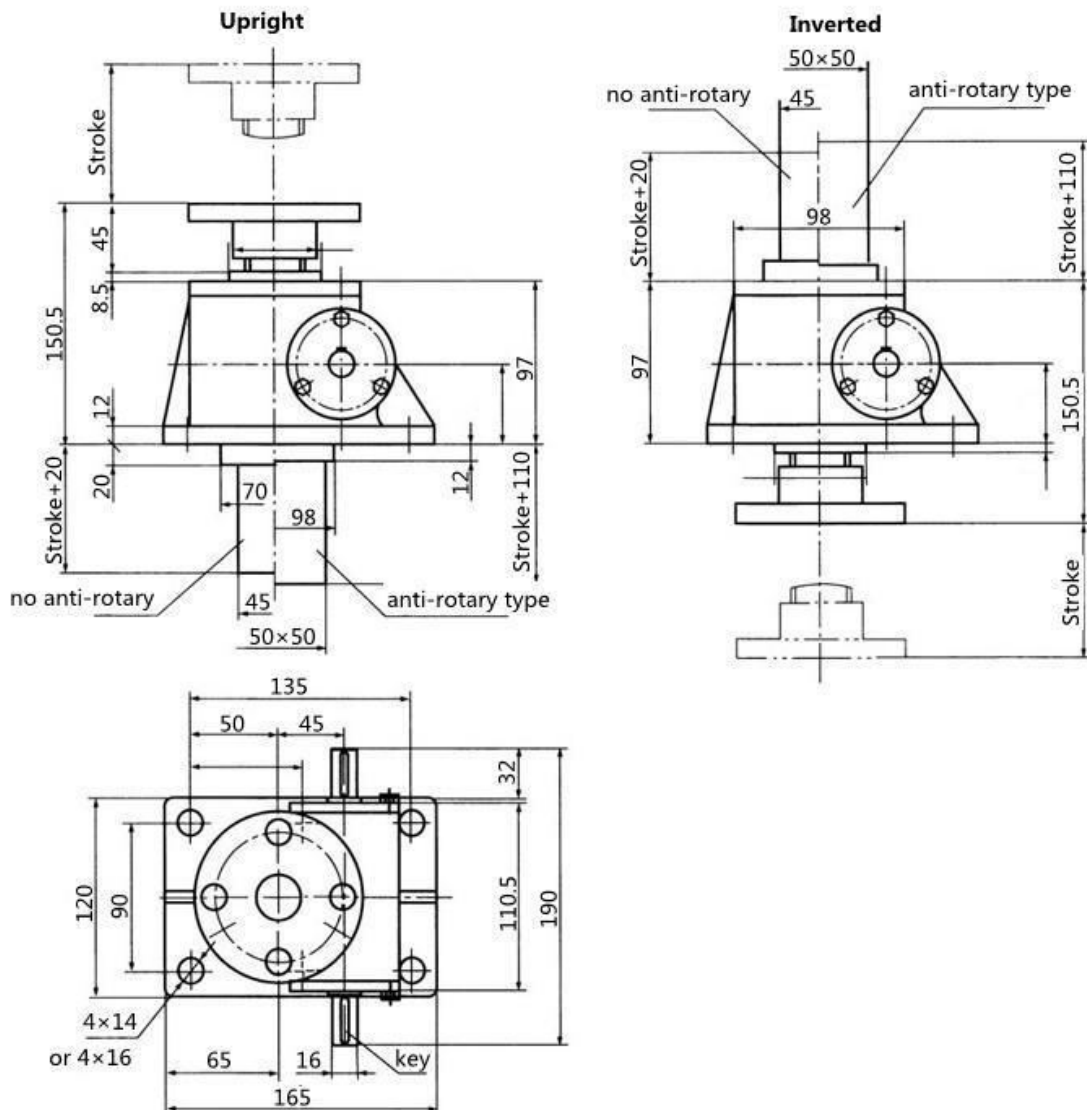

Screw End types and dimensions:

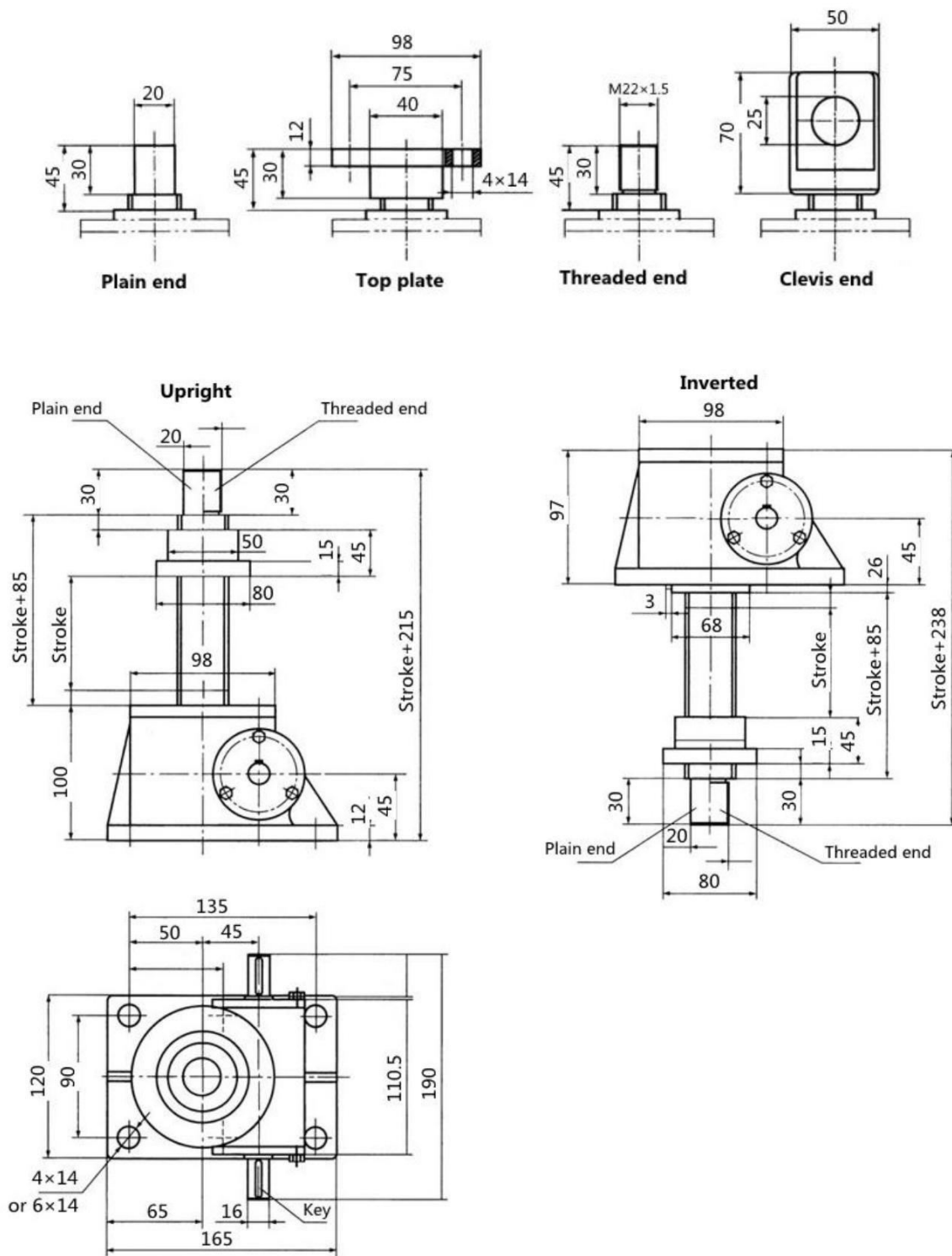

GEC5 Machine Screw Jack Dimensions:

Screw End types and dimensions:

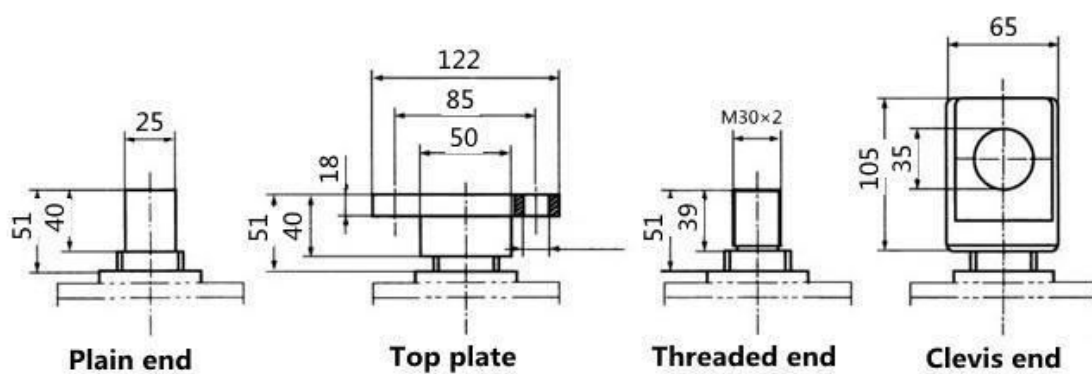

GEC10 Machine Screw Jack Dimensions:

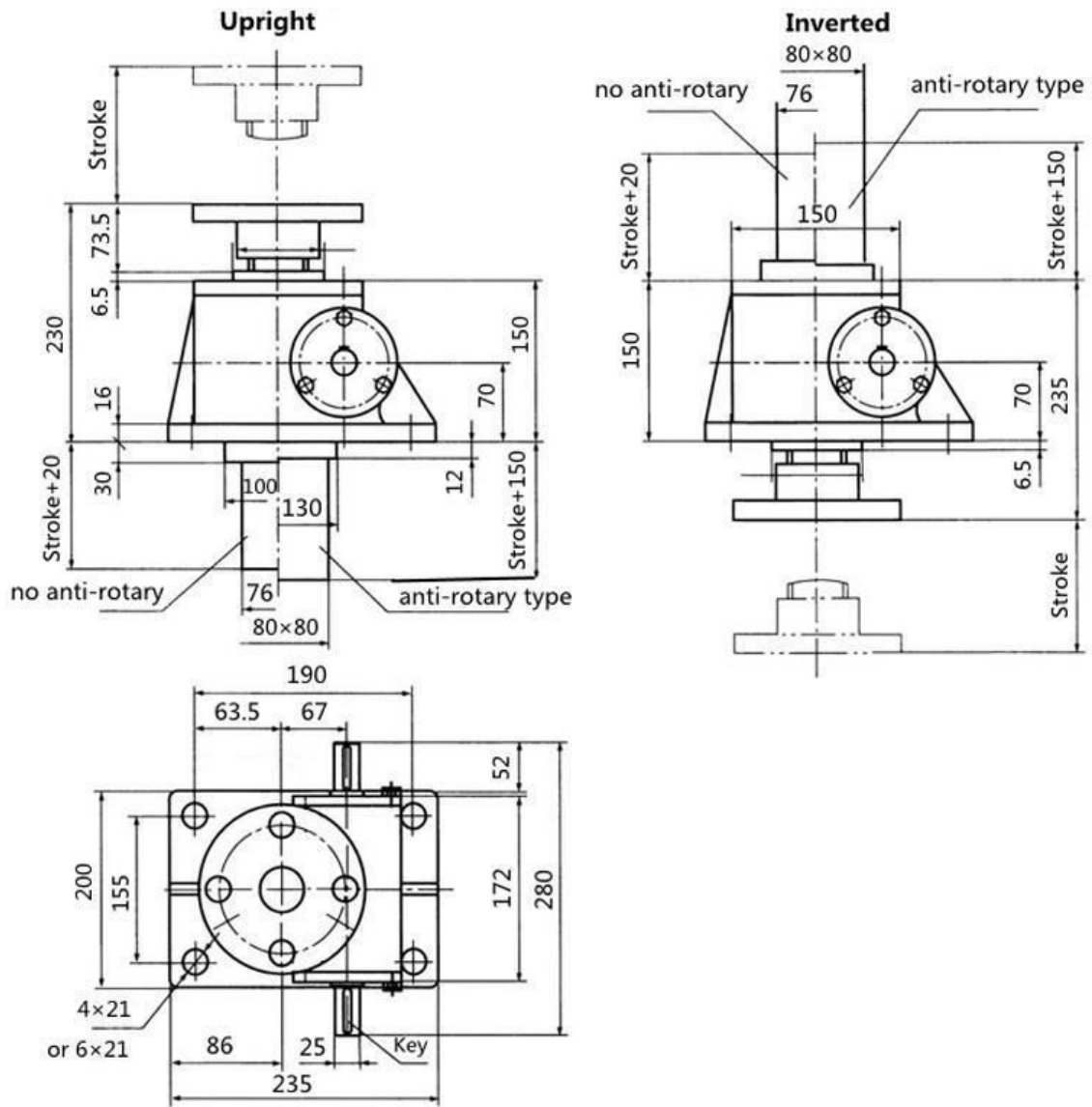

Key: 8×7×45

Screw End types and dimensions:

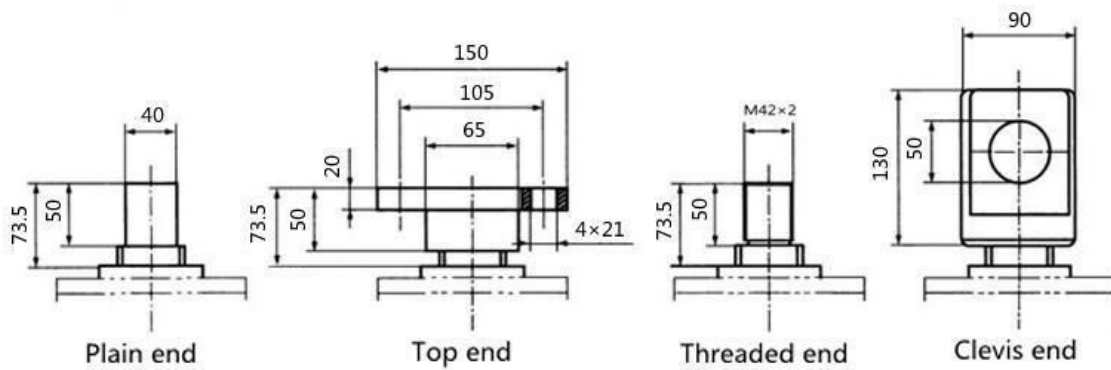

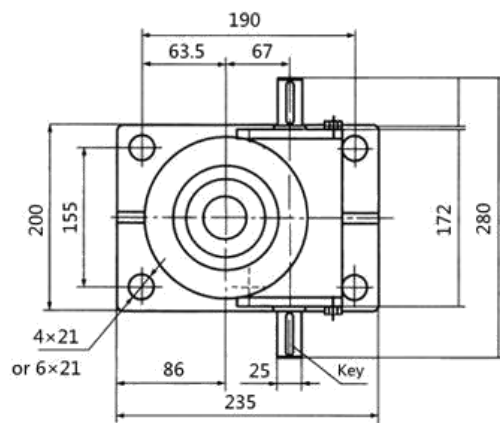
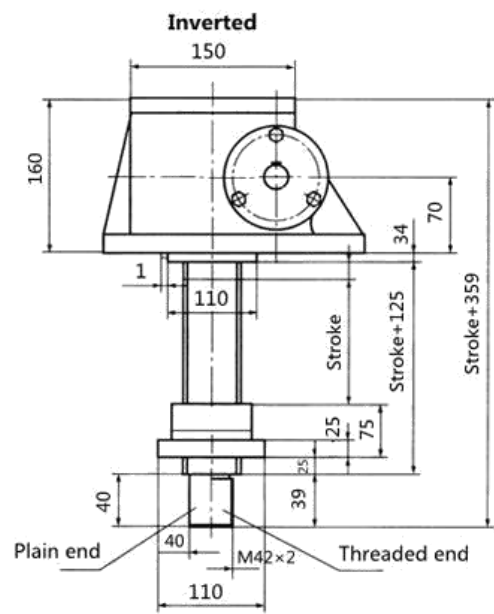
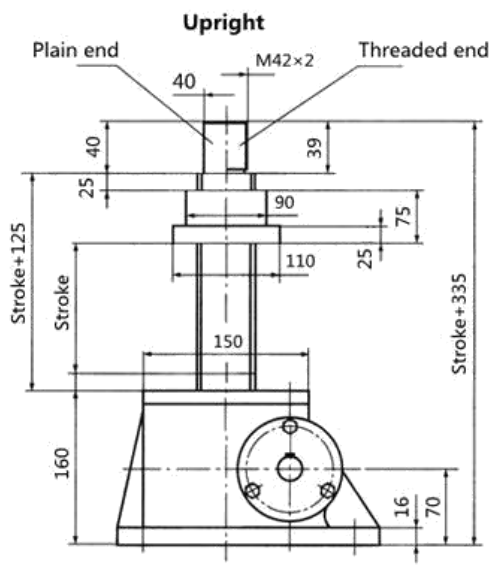

Key: 8x7x45

GEC20 Machine Screw Jack Dimensions:

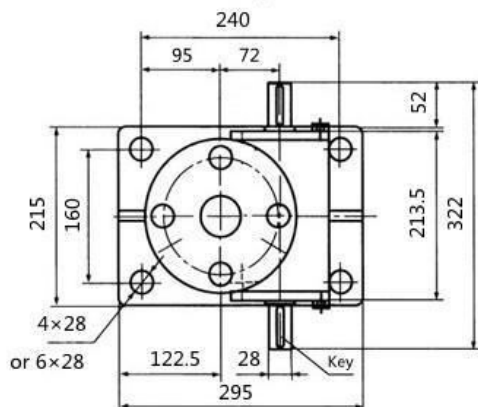
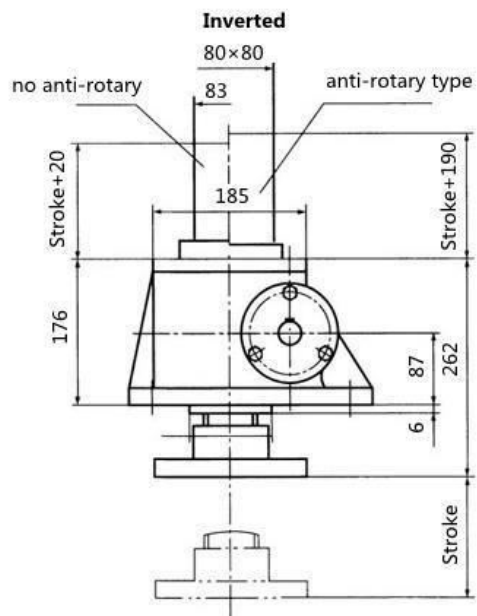
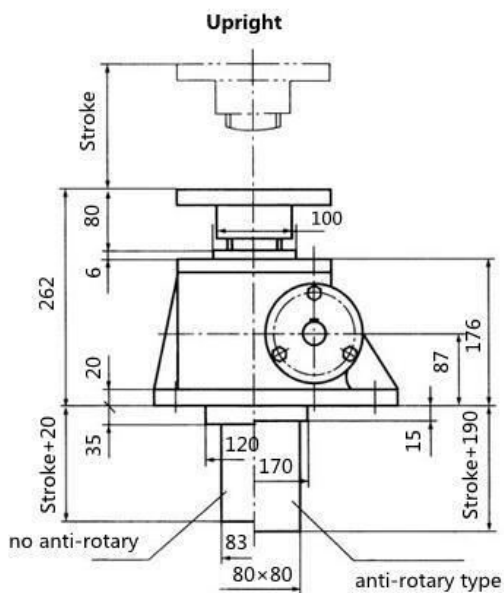

Key: 8×7×45

Screw End types and dimension:

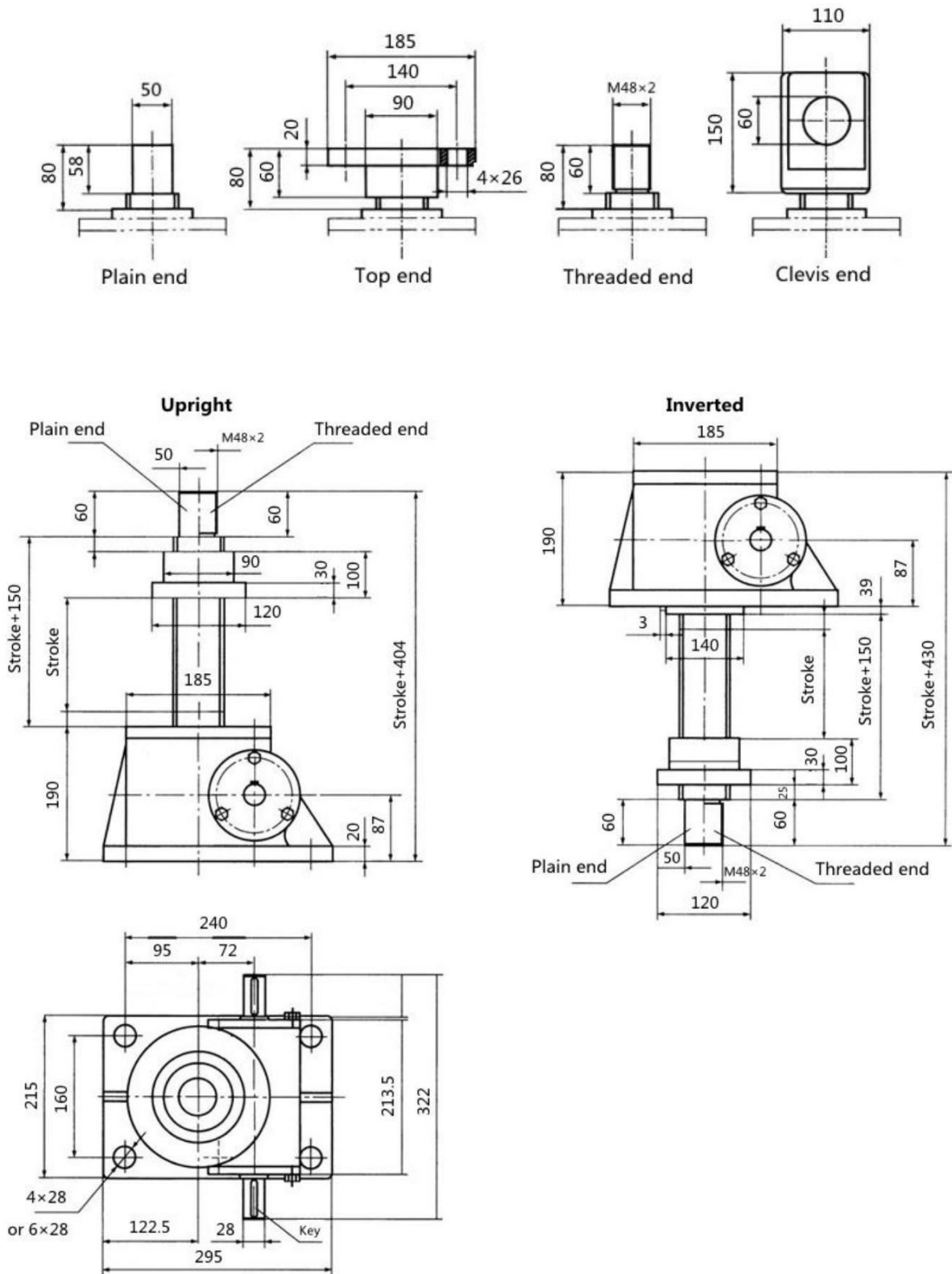

Key: 8×7×45

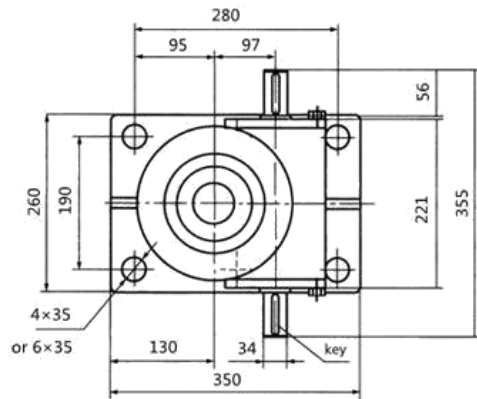
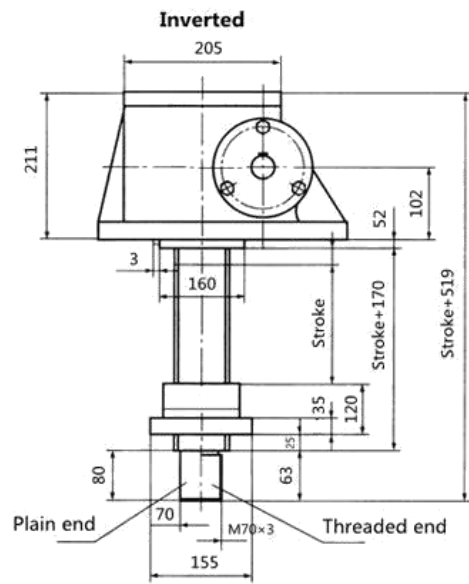
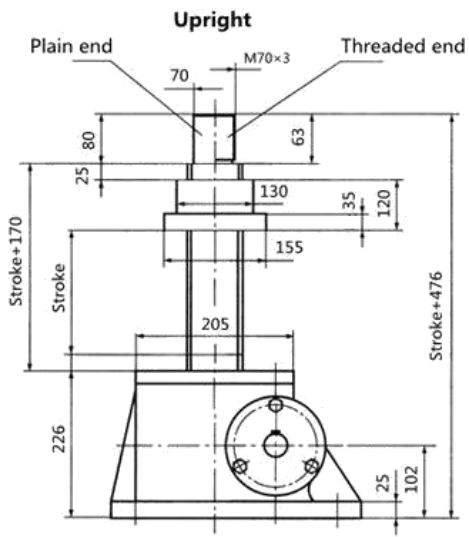

Key: 10x8x50

GEC35 Machine Screw Jack Dimensions:

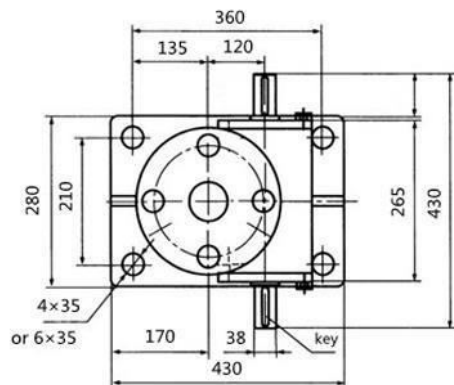
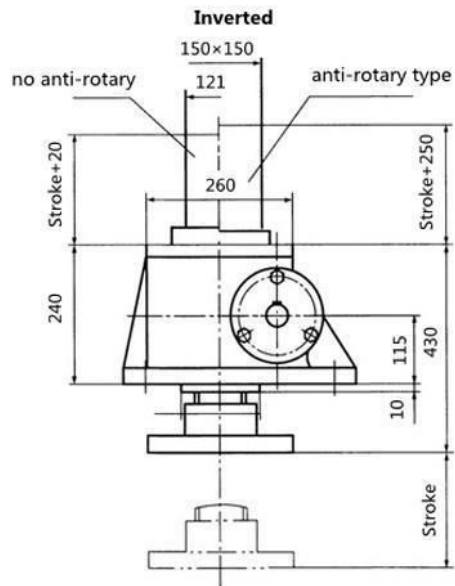
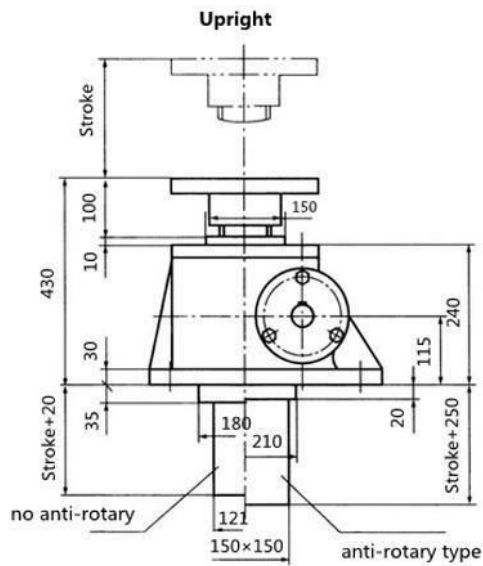

Screw End types and dimension:

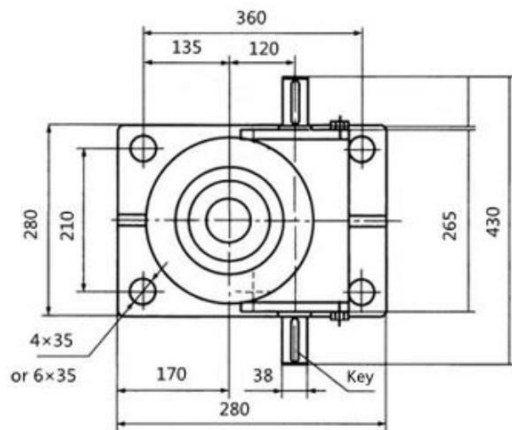
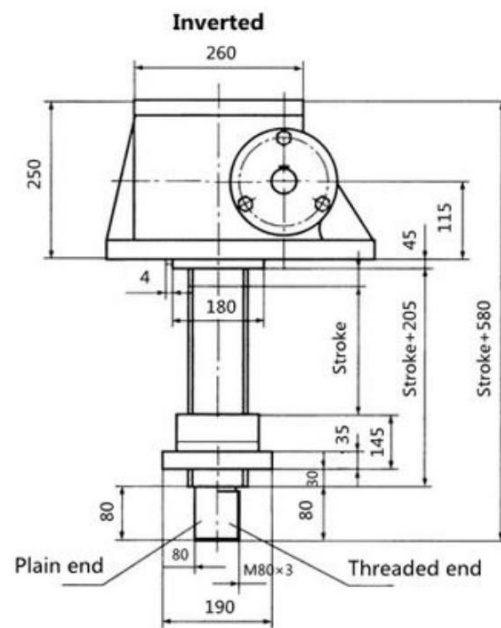
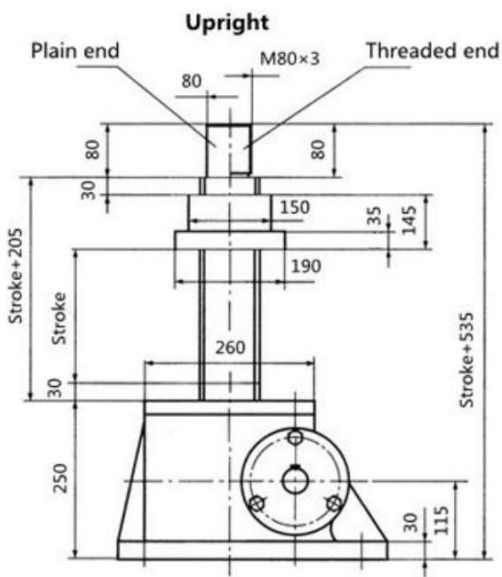
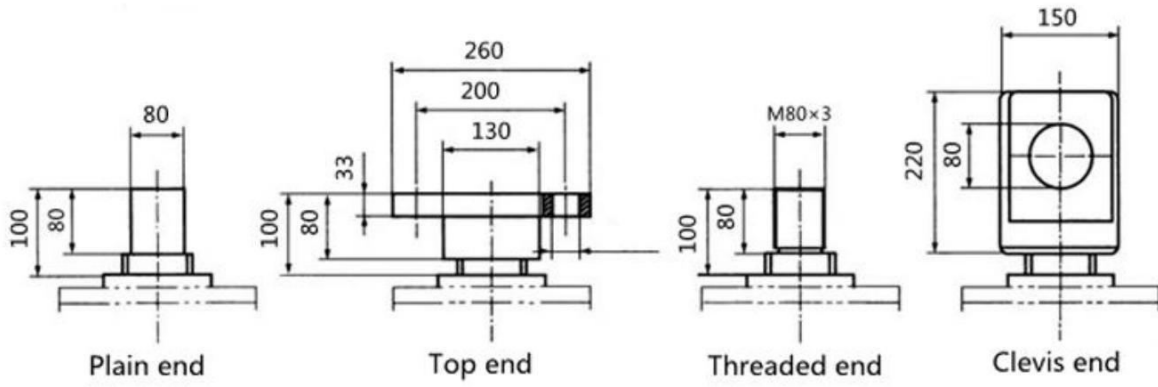

Key: 10x8x70

GEC50 Machine Screw Jack Dimensions:

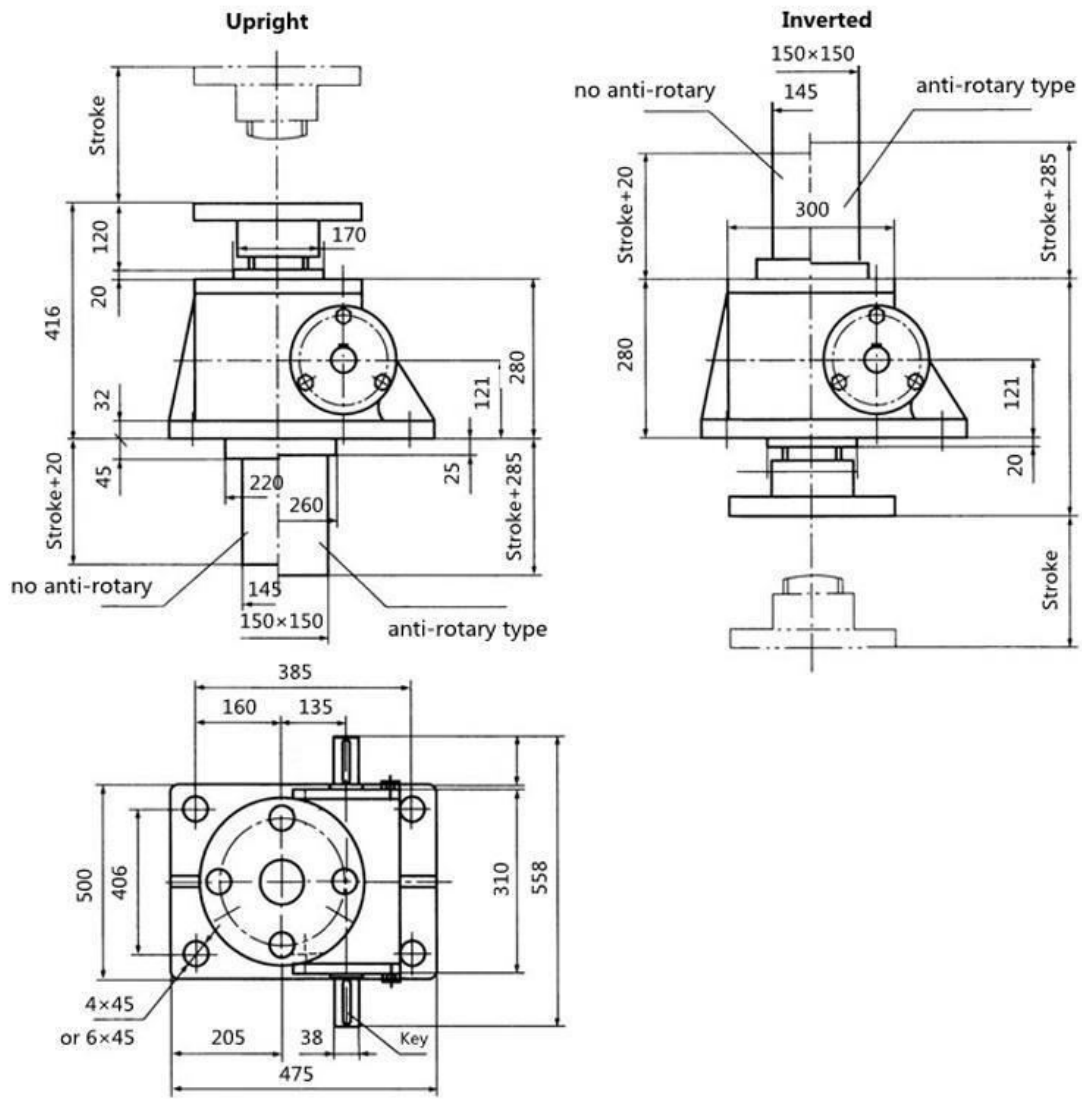

Key: 10x8x90

Screw End types and dimension:

